

# TRUMPET FINGERING CHART

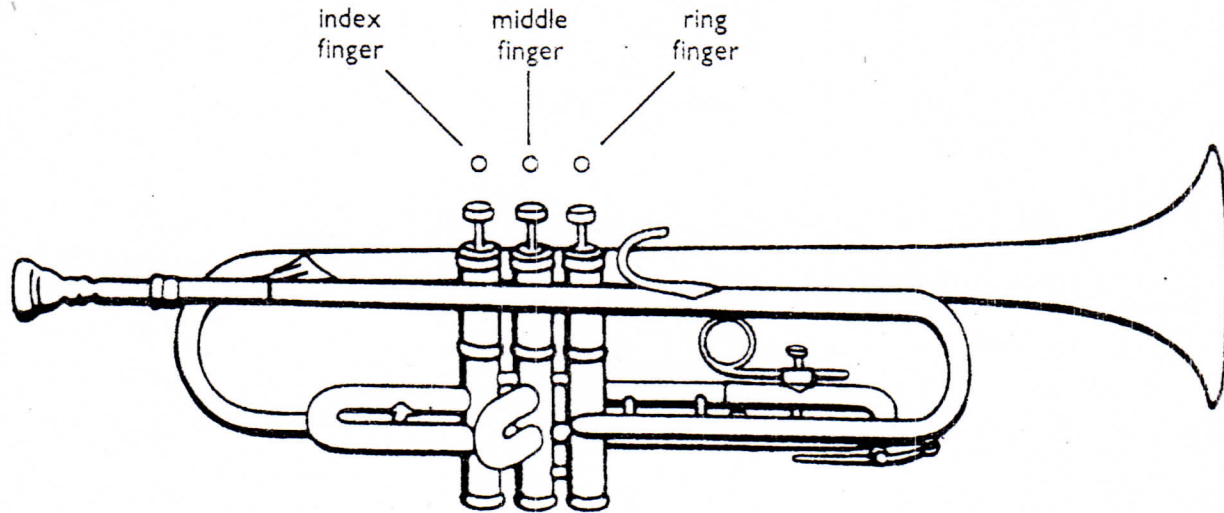

○ = valve up  
● = valve down

**F# Gb G G# Ab A A# Bb B C C# Db D D# Eb**

●●● ●●● ○●● ●●● ●○○ ○○○ ○○○ ●●● ●○○ ○●●

**E F F# Gb G G# Ab A A# Bb B C C# Db D**

●●○ ●○○ ○●○ ○○○ ○●● ●○○ ●○○ ○●○ ○○○ ●●○ ●○○

**D# Eb E F F# Gb G G# Ab A A# Bb B C**

○○○ ○○○ ●○○ ○●○ ○○○ ○●● ●●○ ●○○ ○●○ ○○○

2nd Trumpet

# Waverly Fight Song

for the Waverly Marching Tigers

H. Fillmore

Musical score for 2nd Trumpet, Waverly Fight Song. The score is written in treble clef, 2/4 time, and B-flat major. It consists of seven staves of music. The first staff begins with a measure rest and is marked with a 'V' and 'A'. The second staff starts at measure 5 and is marked with a 'V' and 'B'. The third staff starts at measure 10 and is marked with a 'V'. The fourth staff starts at measure 15 and is marked with a 'V' and 'C'. The fifth staff starts at measure 20 and is marked with a 'V'. The sixth staff starts at measure 25 and is marked with a 'V' and 'D'. The seventh staff starts at measure 30 and is marked with a 'V'. The score concludes with a final measure rest.

A HAL LEONARD PUBLICATION

# FANFARE

By BILL MOFFIT

3rd B<sup>b</sup> CORNET  
Majestically

## THE STAR SPANGLED BANNER

Arr. By BILL MOFFIT

(Key of A<sup>b</sup>)

Trumpet 3

### Hey Song

WHS 1997

Musical score for Trumpet 3 of 'Hey Song'. The score is written in treble clef with a key signature of one sharp (F#) and a 4/4 time signature. It consists of seven staves of music. The first six staves contain a melodic line with various rhythmic patterns, including eighth and sixteenth notes, and rests. The seventh staff features a more complex rhythmic pattern with accents and a dynamic marking of *ff* (fortissimo) at the end. Measure numbers 5, 9, 13, 17, 19, and 25 are indicated at the beginning of their respective staves. A first ending bracket labeled '1' spans measures 19-24, and a second ending bracket labeled '2' spans measures 25-28.

2nd Trumpet

### Tiger Rag WHS Band 1997

for Marching Band

Musical score for 2nd Trumpet of 'Tiger Rag'. The score is written in treble clef with a key signature of two flats (Bb) and a 4/4 time signature. It consists of six staves of music. The first staff begins with a four-measure rest followed by a melodic line. The second and third staves continue the melodic line with various rhythmic patterns and accents. The fourth staff includes a section labeled 'B' and features a dynamic marking of *ff* (fortissimo). The fifth and sixth staves continue the melodic line. Measure numbers 7, 13, 19, 25, and 31 are indicated at the beginning of their respective staves.

Cornet 2/3

# Ain't Been Good

"Laid-Back" Blues

6

A

12

20

B

28

35

45

D.S. al Coda

This musical score is for the Cornet 2/3 part of the piece "Ain't Been Good". It is a "Laid-Back" Blues in 4/4 time. The score consists of six staves of music. The first staff starts with a treble clef, a key signature of one flat (B-flat), and a 4/4 time signature. It begins with a sixteenth rest, followed by a series of notes including a sixteenth note G4, a quarter note F4, a quarter note E4, a quarter note D4, a quarter note C4, and a quarter note B3. A first ending bracket labeled 'A' spans measures 6 through 11. The second staff continues the melody. The third staff features a second ending bracket labeled 'B' from measure 20 to 27. The fourth staff continues the melody. The fifth staff includes a measure rest (marked with a circled theta symbol) in measure 35, followed by a sixteenth rest and a sixteenth note G4. The sixth staff begins with a circled theta symbol and continues the melody. The piece concludes with the instruction "D.S. al Coda".

3rd Trumpet

# Hang On Sloopy

for the Waverly Marching Band

Arr. by Tatgenhorst

9

B 2

15

23

30

D

34

38

Yeah!

This musical score is for the 3rd Trumpet part of the piece "Hang On Sloopy". It is arranged for the Waverly Marching Band by Tatgenhorst. The score is in 4/4 time and consists of six staves of music. The first staff starts with a treble clef, a key signature of one sharp (F#), and a 4/4 time signature. It begins with a quarter note G4, followed by a quarter note A4, a quarter note B4, and a quarter note C5. The second staff continues the melody. The third staff features a second ending bracket labeled 'B' from measure 15 to 22. The fourth staff continues the melody. The fifth staff features a third ending bracket labeled 'C' from measure 23 to 29. The sixth staff continues the melody. The seventh staff features a fourth ending bracket labeled 'D' from measure 30 to 37. The eighth staff continues the melody and concludes with the instruction "Yeah!".

A HAL LEONARD PUBLICATION

Recorded by BEN E. KING

2nd B♭ TRUMPET

# STAND BY ME

Words and Music by BEN E. KING,  
JERRY LEIBER and MIKE STOLLER  
Arranged by JOHNNIE VINSON

Moderate Rock 'n' Roll

The musical score is written on six staves in 4/4 time with a key signature of one sharp (F#). The tempo is 'Moderate Rock 'n' Roll'. The score includes various musical notations such as rests, eighth notes, quarter notes, and half notes. Dynamics include *f* (forte), *mf* (mezzo-forte), and *ff* (fortissimo). There are several circled areas: a circle around measures 9-17, another around measures 41-49, and a third around measures 49-51. Measure numbers 7, 9, 17, 25, 33, 41, and 49 are boxed. A '6' is written above the first measure of the fifth staff. A '3' is written above measure 33. A '3' is written above measure 49. A triangle symbol is above measure 49. The score ends with a double bar line.

Copyright © 1961 by Progressive Music Publishing Co., Trio Music, Inc. and ADT Enterprises, Inc.  
All rights for the U.S.A. and Canada controlled by Unichappell Music, Inc. (Rightsong Music, publisher)  
This arrangement Copyright © 1987 by Progressive Music Publishing Co., Trio Music Inc. and ADT Enterprises Inc.  
International Copyright Secured ALL RIGHTS RESERVED Printed in the U.S.A.  
Unauthorized copying, arranging, adapting, recording or public performance is an infringement of copyright.  
Infringers are liable under the law.

# AMERICA, THE BEAUTIFUL

3rd B♭ CORNET

SHOWPOWER SERIES

America, The Beautiful  
Words and Music by  
KATHARINE LEE BATES and  
SAMUEL A. WARD  
Taps - TRADITIONAL  
Arranged by BILL MOFFIT

Musical score for 'America, The Beautiful' for 3rd B♭ Cornet. The score is in 4/4 time and consists of four staves. The first staff begins with a dynamic marking of *f* and contains measures 1-4, ending with a repeat sign and a first ending bracket labeled 'A'. The second staff contains measures 5-8, ending with a first ending bracket labeled 'B'. The third staff contains measures 9-12, ending with a first ending bracket labeled '1.' and a dynamic marking of *mf*. The fourth staff contains measures 13-16, starting with a second ending bracket labeled '2.' and a dynamic marking of *ff*, and ending with a dynamic marking of *fp*. The score includes various musical notations such as slurs, accents, and triplets.

# TAPS

Musical score for 'Taps' for 3rd B♭ Cornet. The score is in 4/4 time and consists of two staves. The first staff begins with a dynamic marking of *mp* and contains measures 1-4, ending with a first ending bracket labeled 'A'. The second staff contains measures 5-8, starting with a dynamic marking of *ff* and ending with a dynamic marking of *p*. The score includes various musical notations such as slurs, accents, and fermatas.

Copyright © 1985 by STUDIO 224, Hialeah, Florida  
International Copyright Secured Made In U.S.A. All Rights Reserved

Flugelhorn

# My Town

The Ohio State University Marching Band

arr: Pfaffman '86

Rock  $\text{♩} = 132$

Musical score for Flugelhorn part of 'My Town'. The score is written in 4/4 time with a key signature of one flat (Bb). It consists of ten staves of music, each starting with a measure number in a box. The tempo is marked 'Rock' with a quarter note equal to 132 beats per minute. The score includes various musical notations such as notes, rests, beams, and dynamic markings like *f* and *mf*. There are also some handwritten annotations: a '4' above the first staff and a '5' above the second staff. The piece concludes with a double bar line at the end of the final staff.

1 5

10 13 15 *mf*

17

24

30 *f*

36

41

47 5

58

64



# Trumpet in B $\flat$ 2

# Go Waverly Tigers

$\text{♩} = 120$



Go Waver-ly Ti - gers!



Go Waver-ly Ti - gers! T I G

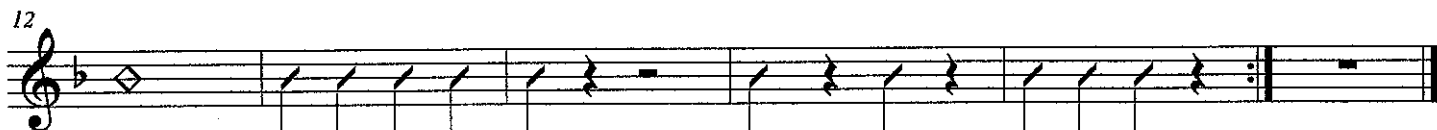

E - R R R R S Waverly! Tigers! W H S!