

# TRUMPET FINGERING CHART

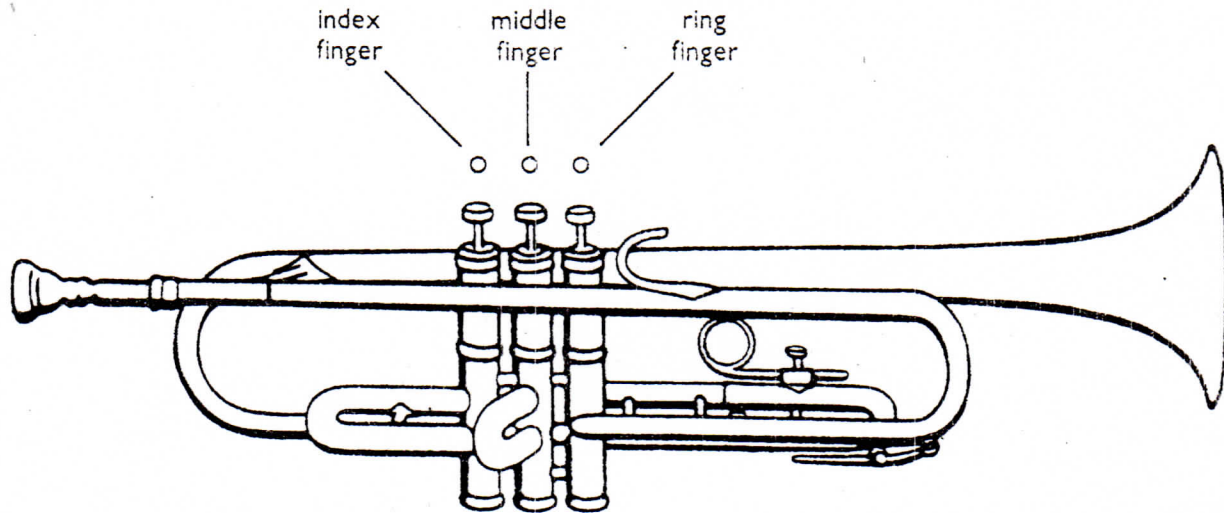

○ = valve up  
● = valve down

**F# Gb G G# Ab A A# Bb B C C# Db D D# Eb**

●●● ●●● ○●● ●●● ●○○ ○○○ ○○○ ●●● ●○○ ○●●

**E F F# Gb G G# Ab A A# Bb B C C# Db D**

●○○ ●○○ ○●● ○○○ ○●● ●○○ ●○○ ○●● ○○○ ●●● ●○○

**D# Eb E F F# Gb G G# Ab A A# Bb B C**

○○○ ○○○ ●○○ ○●● ○○○ ○●● ●●● ●○○ ○●● ○○○

2nd Trumpet

# Waverly Fight Song

for the Waverly Marching Tigers

H. Fillmore

Musical score for 2nd Trumpet, titled "Waverly Fight Song" for the Waverly Marching Tigers, composed by H. Fillmore. The score is written in 4/4 time with a key signature of one flat (Bb). It consists of seven staves of music, with measures numbered 5, 10, 15, 20, 25, 30, and 36. The score is divided into sections A, B, C, and D. Section A spans measures 5-10, Section B spans measures 10-15, Section C spans measures 15-20, and Section D spans measures 20-36. The music features a mix of quarter, eighth, and sixteenth notes, with some measures containing rests. The notation includes dynamic markings such as *v* (vibrato) and *ff* (fortissimo), and articulation marks like accents and slurs. The score concludes with a final double bar line at measure 36.

A HAL LEONARD PUBLICATION

2nd B<sup>b</sup> CORNET

Majestically

# FANFARE

By BILL MOFFIT



## THE STAR SPANGLED BANNER

Arr. By BILL MOFFIT

(Key of A<sup>b</sup>)

The second staff of music is written in treble clef with a key signature of two flats (B-flat and E-flat) and a 3/4 time signature. It begins with a dynamic marking of *f* and a *Majestically* instruction. The melody consists of eighth and sixteenth notes, with some notes beamed together. Performance markings include accents (^) and slurs. The staff is divided into four sections labeled A, B, C, and D. Section A is a short phrase, B and C are longer phrases, and D is a final phrase. The staff concludes with a double bar line and a repeat sign.

Copyright © 1964 by Hal Leonard Music, Inc. 64 East Second Street, Winona, Minnesota.  
International Copyright Secured. Made in U. S. A. All Rights Reserved.

Trumpet 2

Hey Song  
WHS 1997

Musical score for Trumpet 2 of 'Hey Song' (WHS 1997). The score is written in treble clef with a key signature of one sharp (F#) and a 4/4 time signature. It consists of six staves of music. The first staff (measures 1-6) features a rhythmic pattern of quarter notes and rests. The second staff (measures 7-11) continues this pattern. The third staff (measures 12-15) introduces eighth notes and sixteenth notes with accents. The fourth staff (measures 16-20) features eighth notes with accents and first endings. The fifth staff (measures 21-24) includes second endings. The sixth staff (measures 25-30) concludes with eighth notes and a final *ff* dynamic marking.

2nd Trumpet

Tiger Rag WHS Band 1997  
for Marching Band

Musical score for 2nd Trumpet of 'Tiger Rag' (WHS Band 1997, for Marching Band). The score is written in treble clef with a key signature of two flats (Bb, Eb) and a 4/4 time signature. It consists of six staves of music. The first staff (measures 1-6) features a rhythmic pattern of quarter notes and rests, with an accent (^) over the first measure. The second staff (measures 7-12) continues with quarter notes and rests, including accents (^) and breath marks (>). The third staff (measures 13-18) features quarter notes and rests with accents (^) and breath marks (>). The fourth staff (measures 19-24) includes a section labeled 'B' and features quarter notes and rests with accents (^) and breath marks (>). The fifth staff (measures 25-30) features quarter notes and rests with accents (^) and breath marks (>). The sixth staff (measures 31-36) concludes with quarter notes and rests, including accents (^) and breath marks (>).



Cornet 2/3

# Ain't Been Good

"Laid-Back" Blues

6

A

12

20

B

28

35

6

D.S. al Coda

45

This musical score is for the Cornet 2/3 part of the piece "Ain't Been Good". It is a "Laid-Back" Blues in 4/4 time. The score consists of six staves of music. The first staff begins with a measure containing a sixteenth rest (6) and a first ending bracket labeled 'A'. The second staff continues the melody. The third staff has a second ending bracket labeled 'B'. The fourth staff continues the melody. The fifth staff has a measure with a sixteenth rest (6) and a first ending bracket labeled 'A'. The sixth staff is a Coda section starting at measure 45, consisting of five measures of sustained chords.

## Hang On Sloopy

for the Waverly Marching Band

Arr. by Tatgenhorst

2nd Trumpet

9

B 2

17

21

26

30

D

34

38

Yeah!

This musical score is for the 2nd Trumpet part of the piece "Hang On Sloopy". It is arranged for the Waverly Marching Band and is in 4/4 time. The score consists of seven staves of music. The first staff begins with a measure containing a quarter rest (4). The second staff has a first ending bracket labeled 'B' with a '2' below it. The third staff continues the melody. The fourth staff continues the melody. The fifth staff has a first ending bracket labeled 'D'. The sixth staff continues the melody. The seventh staff ends with a measure containing a quarter rest and the word "Yeah!".

A HAL LEONARD PUBLICATION

Recorded by BEN E. KING

2nd B $\flat$  TRUMPET

# STAND BY ME

Words and Music by BEN E. KING,  
JERRY LEIBER and MIKE STOLLER  
Arranged by JOHNNIE VINSON

Moderate Rock 'n' Roll

7 9 17 25 33 41 49

*f* *mf* *f* *ff*

Copyright © 1961 by Progressive Music Publishing Co., Trio Music, Inc. and ADT Enterprises, Inc.  
All rights for the U.S.A. and Canada controlled by Unichappell Music, Inc. (Rightsong Music, publisher)  
This arrangement Copyright © 1987 by Progressive Music Publishing Co., Trio Music Inc. and ADT Enterprises Inc.  
International Copyright Secured ALL RIGHTS RESERVED Printed in the U.S.A.  
Unauthorized copying, arranging, adapting, recording or public performance is an infringement of copyright.  
Infringers are liable under the law.

# AMERICA, THE BEAUTIFUL

46

2nd B♭ CORNET

SHOWPOWER SERIES

America, The Beautiful  
Words and Music by  
KATHARINE LEE BATES and  
SAMUEL A. WARD  
Taps - TRADITIONAL  
Arranged by BILL MOFFITT

Musical score for 2nd B♭ CORNET of 'America, The Beautiful'. The score is in 4/4 time and consists of four staves. The first staff begins with a dynamic marking of *f* and a first ending bracket labeled 'A'. The second staff continues the melody with a dynamic marking of *mf* and a second ending bracket labeled 'B'. The third staff features a first ending bracket labeled '1.' and a dynamic marking of *f*. The fourth staff features a second ending bracket labeled '2.' and a dynamic marking of *mf*. The piece concludes with a final dynamic marking of *fp*. The score includes various musical notations such as slurs, accents, and triplets.

## TAPS

Musical score for 'TAPS'. The score is in 4/4 time and consists of two staves. The first staff begins with a dynamic marking of *mp* and a first ending bracket labeled 'A'. The second staff continues the melody with a dynamic marking of *ff* and a second ending bracket labeled 'B'. The piece concludes with a dynamic marking of *p*. The score includes various musical notations such as slurs, accents, and fermatas.

Copyright © 1985 by STUDIO 224, Hialeah, Florida  
International Copyright Secured Made In U.S.A. All Rights Reserved

Trumpet in B $\flat$  2

Go Waverly Tigers

$\text{♩} = 120$

Go Waver-ly Ti - gers!

6

Go Waver-ly Ti - gers! T I G

12

E - R R R R S Waverly! Tigers! W H S!



