

TRUMPET FINGERING CHART

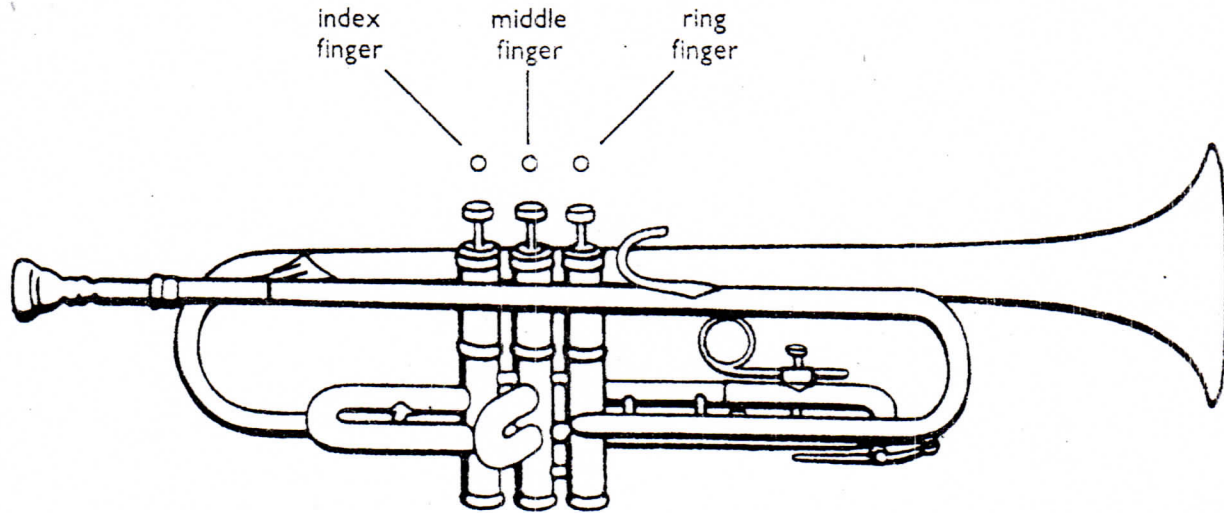

- = valve up
- = valve down

F# Gb G G# Ab A A# Bb B C C# Db D D# Eb

Valve diagrams for the first row: ●●●, ●●○, ○●○, ●●○, ●○○, ○○○, ○○○, ●●●, ●○○, ○●○

E F F# Gb G G# Ab A A# Bb B C C# Db D

Valve diagrams for the second row: ●○○, ●○○, ○●○, ○○○, ○●○, ●○○, ●○○, ○●○, ○○○, ●●○, ●○○

D# Eb E F F# Gb G G# Ab A A# Bb B C

Valve diagrams for the third row: ○○○, ○○○, ●○○, ○●○, ○○○, ○●○, ●●○, ●○○, ○●○, ○○○

1st Trumpet

Waverly Fight Song

for the Waverly Marching Tigers

H. Fillmore

The musical score is written for a 1st Trumpet in G major (one sharp) and 4/4 time. It consists of seven staves of music. The first staff begins with a treble clef, a key signature of one sharp (F#), and a 4/4 time signature. The piece is divided into four sections: Section A (measures 1-4), Section B (measures 5-8), Section C (measures 9-12), and Section D (measures 13-16). Measure numbers 5, 10, 15, 20, 25, and 30 are indicated on the left side of the staves. The music features a mix of quarter, eighth, and sixteenth notes, with some measures containing rests. Dynamic markings such as accents (v) and slurs are used throughout. The score concludes with a final measure on the seventh staff.

A HAL LEONARD PUBLICATION

1st B \flat CORNET

Majestically

FANFARE

By BILL MOFFIT



THE STAR SPANGLED BANNER

Arr. By BILL MOFFIT

(Key of A \flat)

The second through sixth staves continue the fanfare. The second staff includes rehearsal marks A, B, and C. The third staff includes rehearsal mark B. The fourth staff includes rehearsal mark D. The fifth and sixth staves conclude the piece with a final fermata.

Copyright © 1964 by Hal Leonard Music, Inc. 64 East Second Street, Winona, Minnesota.
International Copyright Secured. Made in U. S. A. All Rights Reserved.

Trumpet 1

Hey Song

WHS 1997

Musical score for Trumpet 1 of 'Hey Song'. The score is written in treble clef with a key signature of one sharp (F#) and a 4/4 time signature. It consists of six staves of music. The first staff (measures 1-6) features a rhythmic pattern of quarter notes and rests. The second staff (measures 7-11) continues this pattern. The third staff (measures 12-14) introduces eighth notes with accents. The fourth staff (measures 15-18) continues the eighth-note pattern. The fifth staff (measures 19-24) includes first and second endings, marked with '1' and '2' above the staff. The sixth staff (measures 25-30) concludes with a dynamic marking of *ff* (fortissimo) and a hairpin crescendo leading to the final measure.

1st Trumpet

Tiger Rag WHS Band 1997

for Marching Band

Musical score for 1st Trumpet of 'Tiger Rag'. The score is written in treble clef with a key signature of two flats (Bb) and a 4/4 time signature. It consists of six staves of music. The first staff (measures 1-6) features a rhythmic pattern of quarter notes and rests, with a dynamic marking of *f* (forte) and accents. The second staff (measures 7-12) continues the pattern. The third staff (measures 13-18) continues the pattern. The fourth staff (measures 19-24) includes a section marked 'B' and features a dynamic marking of *f* and accents. The fifth staff (measures 25-30) continues the pattern. The sixth staff (measures 31-36) concludes with a dynamic marking of *f* and accents.

Cornet 1

Ain't Been Good

"Laid-Back" Blues

Musical score for Cornet 1 of "Ain't Been Good". The score is written in treble clef with a key signature of one sharp (F#) and a 4/4 time signature. It consists of six staves of music. The first staff begins with a measure rest of 6 measures, followed by a series of eighth and quarter notes. A first ending bracket labeled 'A' with a repeat sign covers measures 10-11. The second staff continues the melody with eighth and quarter notes. A second ending bracket labeled 'B' covers measures 18-19. The third staff continues the melody with quarter and eighth notes. The fourth staff begins with a measure rest of 6 measures, followed by a series of eighth and quarter notes. The fifth staff continues the melody with quarter and eighth notes. The sixth staff begins with a measure rest of 4 measures, followed by a series of quarter notes. The score concludes with the instruction "D.S. al Coda".

Hang On Sloopy

for the Waverly Marching Band

1st Trumpet

Arr. by Tatgenhorst

Musical score for 1st Trumpet of "Hang On Sloopy". The score is written in treble clef with a key signature of one sharp (F#) and a 4/4 time signature. It consists of seven staves of music. The first staff begins with a measure rest of 4 measures, followed by a series of quarter notes. The second staff continues the melody with quarter notes. The third staff begins with a measure rest of 4 measures, followed by a series of eighth notes. The fourth staff continues the melody with eighth notes and includes a triplet of eighth notes. The fifth staff continues the melody with eighth notes and includes a triplet of eighth notes. The sixth staff continues the melody with eighth notes and includes a triplet of eighth notes. The seventh staff continues the melody with eighth notes and includes a triplet of eighth notes. The score concludes with the instruction "Yeah!".

A HAL LEONARD PUBLICATION

Recorded by BEN E. KING

CWIL

1st B♭ TRUMPET

STAND BY ME

Words and Music by BEN E. KING,
JERRY LEIBER and MIKE STOLLER
Arranged by JOHNNIE VINSON

Moderate Rock 'n' Roll

The musical score for the 1st B♭ Trumpet part of "Stand By Me" is written in 4/4 time with a key signature of one sharp (F#). The score consists of six staves of music. The first staff begins with a measure rest followed by a measure with a fermata, then a measure with a dynamic marking of *f* and a measure rest. A box containing the number 7 is placed above the first measure, and a box containing the number 9 is placed above the second measure. The second staff continues with a measure rest, a measure with a dynamic marking of *mf*, and a measure rest. A box containing the number 17 is placed above the second measure. The third staff begins with a measure rest, a measure with a dynamic marking of *f*, and a measure rest. A box containing the number 25 is placed above the second measure. The fourth staff begins with a measure rest, a measure with a dynamic marking of *f*, and a measure rest. A box containing the number 33 is placed above the second measure, and a box containing the number 3 is placed above the third measure. The fifth staff begins with a measure rest, a measure with a dynamic marking of *f*, and a measure rest. A box containing the number 41 is placed above the second measure. The sixth staff begins with a measure rest, a measure with a dynamic marking of *ff*, and a measure rest. A box containing the number 49 is placed above the second measure, and a box containing the number 3 is placed above the third measure.

Copyright © 1961 by Progressive Music Publishing Co., Trio Music, Inc. and ADT Enterprises, Inc.
All rights for the U.S.A. and Canada controlled by Unichappell Music, Inc. (Rightsong Music, publisher)
This arrangement Copyright © 1987 by Progressive Music Publishing Co., Trio Music Inc. and ADT Enterprises Inc.
International Copyright Secured ALL RIGHTS RESERVED Printed in the U.S.A.
Unauthorized copying, arranging, adapting, recording or public performance is an infringement of copyright
Infringers are liable under the law.

AMERICA, THE BEAUTIFUL

1st B♭ CORNET



America, The Beautiful
Words and Music by
KATHARINE LEE BATES and
SAMUEL A. WARD
Taps - TRADITIONAL
Arranged by BILL MOFFIT

Musical score for 1st B♭ Cornet of "America, The Beautiful". The score is in 4/4 time and consists of four staves. The first staff begins with a dynamic marking of *f* and contains a measure marked with a boxed letter 'A'. The second staff contains a measure marked with a boxed letter 'B'. The third staff contains a measure marked with a boxed letter 'C' and a first ending bracket labeled '1.'. The fourth staff contains a second ending bracket labeled '2.' and a dynamic marking of *fp*. The score includes various musical notations such as slurs, accents, and triplets.

TAPS

Musical score for "Taps". The score is in 2/4 time and consists of two staves. The first staff begins with a dynamic marking of *mp* and contains a measure marked with a boxed letter 'A'. The second staff contains a measure marked with a boxed letter 'B' and a dynamic marking of *ff*. The score includes various musical notations such as slurs and accents.

Copyright © 1985 by STUDIO 224, Hialeah, Florida
International Copyright Secured Made In U.S.A. All Rights Reserved

B♭ Trumpet 1

"My Town"

The Ohio State University Marching Band

arr. Pfaffman '86
Edited by Seth Justice

Rock ♩ = 132

Musical score for B♭ Trumpet 1, "My Town". The score is written in 4/4 time with a key signature of one flat (B♭). The tempo is marked "Rock ♩ = 132". The score consists of ten staves of music, with measure numbers 8, 13, 20, 26, 32, 38, 44, 55, 61, and 68 indicated at the beginning of their respective staves. The music features various dynamics including *f* (forte), *mf* (mezzo-forte), and *pp* (pianissimo). There are also accents (>) and slurs throughout the piece. The score ends with a double bar line at the end of the final staff.

Trumpet in B \flat 1 Go Waverly Tigers

$\text{♩} = 120$



Go Waver-ly Ti - gers!



Go Waver-ly Ti - gers! T I G

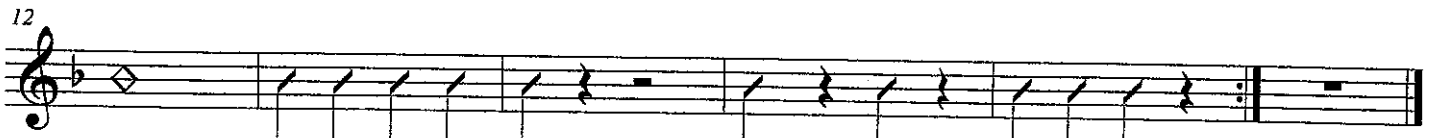

E - R R R R S Waverly! Tigers! W H S!