

# TRUMPET FINGERING CHART

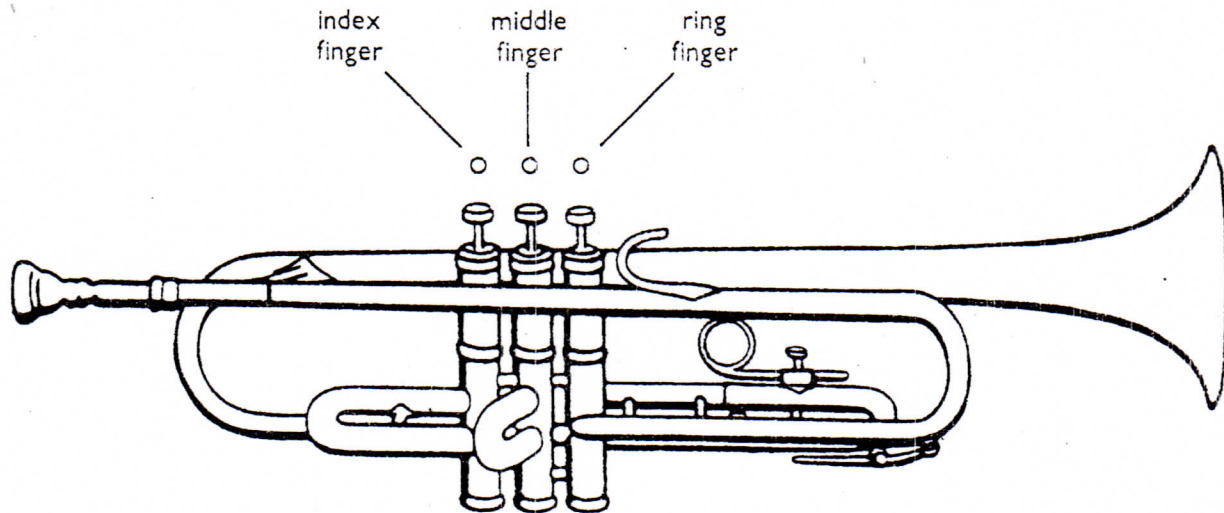

○ = valve up  
● = valve down

F# Gb G G# Ab A A# Bb B C C# Db D D# Eb

●●● ●●● ○●● ●●● ●○○ ○○○ ○○○ ●●● ●○○ ○●●

E F F# Gb G G# Ab A A# Bb B C C# Db D

●○○ ●○○ ○●● ○○○ ○●● ●○○ ●○○ ○●● ○○○ ●●● ●○○

D# Eb E F F# Gb G G# Ab A A# Bb B C

○○○ ○○○ ●○○ ○●● ○○○ ○●● ●●● ●○○ ○●● ○○○

French Horn

# Waverly Fight Song

for the Waverly Marching Tigers

H. Fillmore

The musical score is written for French Horn in 2/4 time, featuring a key signature of two flats (B-flat and E-flat). The piece is divided into four distinct sections labeled A, B, C, and D. Section A begins at the first staff. Section B starts at the fifth measure. Section C begins at the tenth measure. Section D starts at the twenty-fifth measure. The score includes various musical notations such as quarter notes, eighth notes, and rests, with dynamic markings like accents (>) and slurs. The piece concludes with a final note and a fermata.

A HAL LEONARD PUBLICATION

1st and 2nd F HORNS

# FANFARE

By BILL MOFFIT

Majestically

*f* rit. a tempo rit.

## THE STAR SPANGLED BANNER

Arr. By BILL MOFFIT

(Key of A $\flat$ )

A B C D

Copyright © 1964 by Hal Leonard Music, Inc. 64 East Second Street, Winona, Minnesota.  
International Copyright Secured. Made in U. S. A. All Rights Reserved.

Horns

### Hey Song

WHS 1997

Musical score for Horns of "Hey Song" (WHS 1997). The score is written in 4/4 time and consists of seven staves. The key signature has two flats (B-flat and E-flat). The music features a mix of eighth and quarter notes, with some measures containing rests. A dynamic marking of *ff* (fortissimo) is present at the end of the piece. Measure numbers 5, 8, 11, 15, 19, and 25 are indicated at the beginning of their respective staves. There are first and second endings marked with "1" and "2" above the staff at measures 19 and 20.

French Horn

### Tiger Rag WHS Band 1997

for Marching Band

Musical score for French Horn of "Tiger Rag" (WHS Band 1997, for Marching Band). The score is written in 4/4 time and consists of six staves. The key signature has two flats (B-flat and E-flat). The music features a mix of eighth and quarter notes, with some measures containing rests. A dynamic marking of *ff* (fortissimo) is present at the end of the piece. Measure numbers 7, 13, 19, 25, and 31 are indicated at the beginning of their respective staves. There are first and second endings marked with "A" and "B" above the staff at measures 4 and 19.

F Horn

# Ain't Been Good

"Laid-Back" Blues

Musical score for F Horn of "Ain't Been Good". The score is in 4/4 time and consists of five staves of music. The first staff starts with a treble clef, a key signature of one flat (Bb), and a common time signature. It features a series of eighth and quarter notes with accents. The second staff begins with a measure rest and a boxed 'A' section marker. The third staff continues the melodic line. The fourth staff starts with a boxed 'B' section marker and includes a measure rest. The fifth staff concludes with a double bar line and a '2' indicating a second ending. The instruction "D.S. al Coda" is written below the final staff.

## Hang On Sloopy

for the Waverly Marching Band

Horns

Arr. by Tatgenhorst

Musical score for Horns of "Hang On Sloopy". The score is in 4/4 time and consists of seven staves of music. The first staff starts with a treble clef, a key signature of one flat (Bb), and a 4/4 time signature. It features a series of eighth and quarter notes. The second staff includes a boxed 'B' section marker and a '2' indicating a second ending. The third staff continues the melodic line. The fourth staff starts with a boxed 'C' section marker. The fifth staff includes a boxed 'D' section marker. The sixth staff continues the melodic line. The seventh staff concludes with a double bar line and the instruction "Yeah!".

A HAL LEONARD PUBLICATION

Recorded by BEN E. KING

F HORN

# STAND BY ME

Words and Music by BEN E. KING,  
JERRY LEIBER and MIKE STOLLER  
Arranged by JOHNNIE VINSON

Moderate Rock 'n' Roll  
8 9

The musical score for the F Horn part of 'Stand By Me' is written in 4/4 time. It consists of six staves of music. The first staff begins with a treble clef and a key signature of one flat (Bb). The tempo is marked 'Moderate Rock 'n' Roll' with a metronome marking of 8. The first measure is marked with a box containing the number 8, and the second measure with a box containing 9. The dynamic marking *mf* is placed below the first staff. The second staff starts with a box containing 17 and a dynamic marking of *f*. The third staff starts with a box containing 25. The fourth staff starts with a box containing 33 and features three triplet markings (indicated by a bracket with the number 3) over the first three measures of that staff, with a dynamic marking of *f*. The fifth staff starts with a box containing 41 and features a triplet marking over the first three measures, with a dynamic marking of *(f)*. The sixth staff starts with a box containing 49 and features a triplet marking over the first three measures, with a dynamic marking of *ff*. The score concludes with a double bar line.

Copyright © 1961 by Progressive Music Publishing Co., Trio Music, Inc. and ADT Enterprises, Inc.  
All rights for the U.S.A. and Canada controlled by Unichappell Music, Inc. (Rightsong Music, publisher)  
This arrangement Copyright © 1967 by Progressive Music Publishing Co., Trio Music Inc. and ADT Enterprises Inc.  
International Copyright Secured ALL RIGHTS RESERVED Printed in the U.S.A.  
Unauthorized copying, arranging, adapting, recording or public performance is an infringement of copyright.  
Infringers are liable under the law.

K.B.

40

# AMERICA, THE BEAUTIFUL

HORN IN F

America, The Beautiful  
Words and Music by  
KATHARINE LEE BATES and  
SAMUEL A. WARD  
Taps - TRADITIONAL  
Arranged by BILL MOFFIT

ENCORE SERIES

Musical score for 'America, The Beautiful' for Horn in F. The score consists of four staves of music. The first staff begins with a forte (*f*) dynamic and includes a first ending bracket labeled 'A'. The second staff includes a second ending bracket labeled 'B'. The third staff includes a first ending bracket labeled '1.' and a second ending bracket labeled '2.'. The fourth staff includes a section labeled 'C' with triplets and a fortissimo (*ff*) dynamic.

# TAPS

Musical score for 'Taps' for Horn in F. The score consists of two staves of music. The first staff includes a section labeled 'A' with a four-measure rest and a mezzo-piano (*mp*) dynamic, and a section labeled 'B' with a fortissimo (*ff*) dynamic. The second staff includes a piano (*p*) dynamic and a mezzo-piano (*mp*) dynamic.

Copyright © 1985 by STUDIO 224, Hialeah, Florida  
International Copyright Secured Made In U.S.A. All Rights Reserved

Horn in F

# "My Town"

The Ohio State University Marching Band

arr. Pfaffman '86  
Edited by Seth Justice

Rock ♩ = 132

4

9 *f*

15 *mf*

20

25

31 *mf*

38

44

51

57

*F Horn*

**My Town**

63

Detailed description: This is a musical score for the Horn in F part of the piece "My Town". The score is written on ten staves of music. The key signature has two flats (B-flat and E-flat), and the time signature is 4/4. The tempo is marked "Rock" with a quarter note equal to 132 beats per minute. The score begins with a dynamic marking of *f* (forte) and a handwritten number "4" above the first staff. Subsequent staves are numbered 9, 15, 20, 25, 31, 38, 44, 51, and 57. Dynamic markings include *mf* (mezzo-forte) at measures 15 and 31. The piece concludes with a handwritten section labeled "F Horn" and the title "My Town" in bold, starting at measure 63. The score includes various musical notations such as eighth and sixteenth notes, rests, and accents.



Horn in F

# Go Waverly Tigers

♩ = 120

Go Waver-ly Ti - gers!

6

Go Waver-ly Ti - gers! T I G

12

E - R R R R S Waverly! Tigers! W H S!